

Sensing Structural Borne Noise in Solid State Materials and Related Applications

Thomas PETZSCHE

Kistler Instrumente GmbH, Sindelfingen

Kontakt E-Mail: thomas.petzsche@kistler.com

Abstract. Basically two principles are currently used to characterize structural borne noise in solid state materials besides laser vibrometry. In the lower frequency range it is the old seismic transducer as it is used in the classic accelerometer tuned to 20 kHz and sometimes using the resonance frequency range up to 100 kHz. In the higher frequency ranges from 50 kHz to 900 kHz usually the Acoustic Emission (AE) sensor is used. Both sensor principles are introduced.

Accelerometers are in use for many applications such as operational, environmental, structural or durability testing, and are requiring more and more triaxial IEPE accelerometers with higher frequency operation - in the three orthogonal directions, for shock and vibration. The innovative mounting principle for Kistler's miniature PiezoStar® and Piezoceramic triaxial cube accelerometer families offers a practical solution and improves the frequency calibration method to higher limits tremendously. The seismic elements of these IEPE triaxial accelerometer families have inherent benefits resulting in high resonance frequency where the sensor design provides stud mounting for each orthogonal axis thanks to threaded holes on 3 of the sensor's faces. The calibration methodology will be reviewed supporting frequencies up to 20 kHz, without additional mechanical fixtures which can impact precision measurements.

AE sensors are non-seismic transducers; they detect travelling surface waves and use a probe mechanism with deformation of a piezoelectric ceramic element. AE transducers are in very wide range of applications, such as crack detection in metal sheet forming, tool breakage, cavitation detection and many others.

Kurzfassung. Grundlegend werden heute neben der Laservibrometrie zwei Verfahren zur Messung von Körperschall in Festkörpern eingesetzt. Im Bereich tieferer Frequenzen ist das der traditionelle Beschleunigungssensor nach dem Prinzip des seismischen Aufnehmers. Er kann bis 20 kHz, manchmal aber auch im Resonanzbereich des Sensors bis ca. 100 kHz, eingesetzt werden. Im höheren Frequenzbereich von 50 kHz bis 900 kHz verwendet man den sog. Körperschall - oder im englischen auch „acoustic emission“ - Sensoren. Beide Prinzipien werden noch einmal erläutert.

Beschleunigungssensoren werden vielfältig, bspw. in der Modal- oder Betriebsschwingformanalyse, Struktur- oder Lebensdauertests eingesetzt. Immer mehr werden hier triaxiale Beschleunigungssensoren zur Vibrations- und Stoßmessung bei höheren Frequenzen bis 20 kHz in den drei orthogonalen Richtungen gefordert. Eine neuartige Konstruktion solcher triaxialer Sensoren auf Kristall oder Piezo-Keramik basierend, erlaubt die Montage in den drei Raumrichtungen durch Schraubmontage. Dieses praktische Design ermöglicht die Bestimmung des Frequenzganges der Sensoren in der Kalibrierung zu wesentlichen höheren Grenzfrequenzen. Die seismischen Elemente dieser triaxialen IEPE – Sensoren haben inhärente Vorteile durch sehr hoch abgestimmte Resonanzfrequenzen und die konstruktiv gegebene Möglichkeit den Sensor durch Montagesutzen in allen drei orthogonalen Richtungen direkt, ohne Verwendung eines mechanischen Adapters auf einem Referenzsensor aufzuspannen. Dies erlaubt erstmals die Charakterisierung bis 20 kHz und erhöht die Messgenauigkeit.



AE-Sensoren sind nicht-seismische Aufnehmer. Sie detektieren, die auf der Oberflächen sich ausbreitenden Oberflächenwellen und führen diese Deformationen auf ein piezoelektrischen Keramikelement, um die Welle in ein elektrisches Signal zu wandeln. Für AE-Sensoren gibt es ebenfalls eine Vielzahl von Anwendungen, wie Risserkennung, Werkzeug- oder Formenbruch, Kavitation und viele weitere.

Introduction

Structural borne noise can be measured in very different frequency ranges. Not just one sensor principle is able to acquire those data's. For physical mounted sensors two principles are used nowadays in most cases. In the frequency range up to 20 kHz it is the classical accelerometer with its seismic sensing element mainly based on the piezoelectric effect [1]. Those can be calibrated over a frequency range up to 20 kHz with traceability to National Metrological Institutes (NMI); typical uncertainties are given at approx. 5% or less for single frequency sensitivity points up to 20 kHz. The frequency range up to 50 kHz or bit higher is, on the other end, characterized by a not accountable measurement uncertainty that cannot be given traceability. A frequency signature can be deviated as long as the signal is not overloaded due to an accelerometer seismic element resonance.

Those test results can be quite useful in applications such as measuring structural borne noise of bearings, gear boxes etc. in condition monitoring, pyroshock testing or for crash induced sound sensing during impact testing of automotive structures. In most cases those measurements can be deviated for all three orthogonal axes.

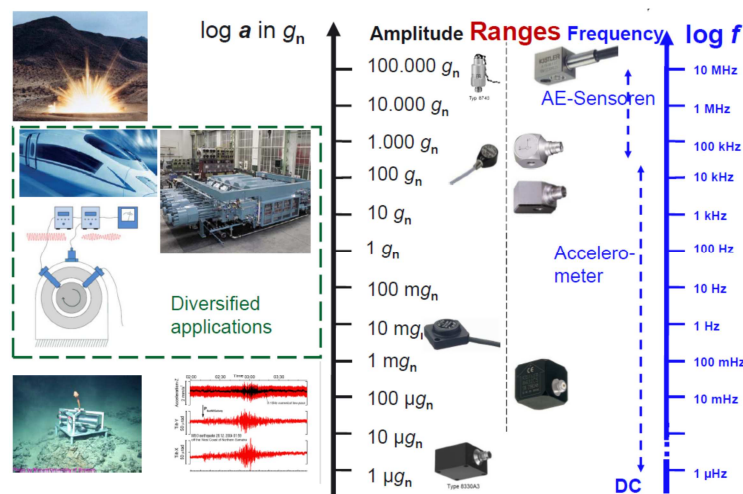

Figure 1. Frequency ranges and amplitudes for accelerometer and AE-sensors.

For higher frequencies from 50 kHz to 1 MHz or even higher, so called acoustic emission (AE) sensors are used. Such high frequency structural borne noise may get generated by crack forming in solid material, improper sealed valves in engines or compressors, particle impacts to or friction between metal sheets, grinding process and others. In all those cases, the generated surface wave is captured by the AE sensor at the surface of a solid state body. The measurement principle is different from measuring acceleration. It cannot be measured in orthogonal directions like an accelerometer would be able to. The sensitivity deviation is very rough and usually expressed in dB deviation to a reference value instead of a percentage. A measurement uncertainty may lie in the order of several dB deviations to a reference point. The goal would be mostly to characterize a frequency signature and correlate certain events to frequency bands in a cause/effect correlation in order to detect certain process events in materials or devices.

The following article will be covering considerations on how to widen triaxial accelerometers frequency response up to 12 kHz or more in order to get a higher precision in sensing structural borne noise. This frequency response characterization is only possible, if mechanical mounting adapters are not used at the interface with the reference accelerometer during the calibration procedure and if the sensors itself has the ability to get rigidly stud mounted in all three axis directly [6].

AE-sensors for higher frequency ranges from 50 kHz to 900 kHz will also be described and a typical application showed. Fig. 1 offers an overview on amplitude and frequency ranges covered by the different sensor technologies and principles.

2. Accelerometers High Frequency Response Characterization in each orthogonal axis

According to ISO EN DIN 16063 standard series [1], the calibration of the frequency response of an accelerometer is performed by primary laser or secondary comparison calibration methods. The characterization of the frequency response above 2...3 kHz becomes more complicated for triaxial accelerometers because of required mechanical adaptations to the reference side of a back-to-back reference standard. Direct mounting is impossible in most cases for the x- and y-direction. Even if Beryllium is used as material, those adaptors are still not stiff enough.

Despite usage of the highest ratio between elastic stiffness and density of any materials, the relative motion between the coupling area of the unit under test (UUT) and the reference accelerometer would still be an issue as both amplitudes cannot be identical. This is illustrated in Fig. 2.

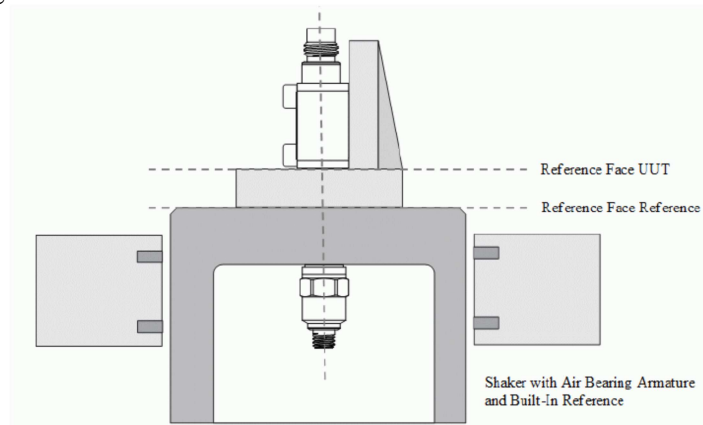

Figure 2. View of a triaxial accelerometer as UUT. Mechanical adapter fixed to the calibration shaker air bearing armature. Built-in reference standard.

The frequency response of a sensor along X and Y axes at higher frequencies will then be limited by the calibration mounting fixture. Therefore, due to the limits of the calibration mounting fixture, performances at high frequency must be specified more conservatively. An estimation of the frequency response in the upper end can often be performed with a resonance excitation of the seismic element (Fig. 6).

Fig. 3 and 4 show a Kistler triaxial accelerometer type 8793A500 and the calibration mounting adaptors that are used with a back-to-back reference standard for different axes on a TIRA S514-C calibration shaker. Fig. 5 shows an overview of the obtained frequency responses up to 2 kHz (x- & y-axes) and to 10 kHz (z-axis). The results of the frequency response in the x-axis and y-axis are mostly influenced by the relative motion between the UUT and the Back-to-Back sensor reference side. In these two axes, the frequency response can be measured only up to 2 kHz. Some improvements can only be achieved by the use of Beryllium mounting adaptors of optimized design. This will be costly for a very slight



Figure 3. Mounting adapters used to calibrate the z-axis (left) and the x- and y-axes (right) of a triaxial accelerometer Kistler type 8793A500 (center).

improvement at higher frequencies. In addition, these adapters would not just be expensive and time consuming to manufacture, but they would also be problematic from the toxicological point of view.

As an alternative to alleviate this issue, the characterization of the resonance frequency in the mounted state can be used as estimation. This method is described in the ISO 5247-14 and -22 and will also be part of a new standard ISO 16063-32 [3, 4].

A rule of thumb is that the 5% frequency response deviation point of the sensor at high frequency is approximately 20% of the mounted resonance frequency. It can be deviated out of the theory of the seismic accelerometer frequency response [1, 5]. This practice offers an alternative method to estimate the frequency response of a sensor used in testing. Figure 6a, b and c show this test and results.

Along with the advantage of three mounting holes, the very rigid crystal element made from PiezoStar® allows measurements up to 12 kHz (+5%) with mounted resonance frequencies up to 70 kHz. As the measurement uncertainty for the sensitivity is much higher beyond 10 kHz, the data sheet specifies an upper frequency response value of 12 kHz with $\pm 5\%$ sensitivity deviations referenced to a specified frequency. This design principle allows a frequency response of 0,5 Hz to 12 kHz and offers a generic use of these sensors in a very wide frequency range where quite often two sensors would have been used in the past.



Figure 4. Mounting a Kistler 8793A500 triaxial accelerometer in z-axis (4a. left) and x-axis (4b. right) to the reference side of a back-to-back reference sensor Kistler 8076K.

In order to solve this problem, triaxial accelerometers have been designed by Kistler which incorporate stud mounting for each orthogonal axis. This is achieved by supplying threaded holes on three sensor faces. This concept has been used for the past 12 years more and more and is currently available in three Kistler sensor families: 8762A, 8763B, 8766A (Fig. 7).

In the following example, a Kistler type 8766A500AB was tested for frequency response from 5 Hz to 50 kHz. The amplitude and phase responses are shown for the x- and z-axes in Fig. 9. In Fig. 9a, the sensitivity deviation was referenced to its sensitivity taken at a frequency of 160 Hz. The results for the y-axis are qualitatively identical to the z-axis. We can observe some minor resonances above 10 kHz with less than 7% sensitivity deviation. The rest of the spectrum is linear and the slope of the entire frequency response is nearly zero percent, as opposed to the response of soft piezoelectric ceramic element material coupled with an internal charge amplifier. The frequency response in Figure 9 shows this response. Frequency response and phase between axes match very closely over the entire frequency range.

Figure 8a shows a Kistler 8766A500AB mounted on a SPEKTRA SE-09 calibration shaker with a single stud. In this setup, the reference sensor is integrated into the shaker armature (Fig. 2). Both reference faces of the UUT as well as the reference sensor are assembled directly together and a relative motion is almost impossible. The calibration equipment being used was traceable to an NMI up to a 20 kHz frequency limit. In our case the reference standard frequency response above 20 kHz has been modeled with a 70 kHz resonance at 20 dB sensitivity increase.

The overall measurement uncertainty for the UUT is 1% up to 1,25 kHz, 2% from 1,25 kHz to 5 kHz and 3% from 5 kHz to 10 kHz, using $k=2$ (95% coverage factor). The result above 20 kHz is then purely qualitative due to the fact that an uncertainty cannot be specified. The occurrence of additional smaller resonances below the main resonance and the deviations from the ideal frequency response may have a different cause than the UUT; i.e. rocking motions of the shaker armature in relation to a cross axis sensitivity of the UUT as one possibility. But these potential error sources have not been subjected to detailed investigations.

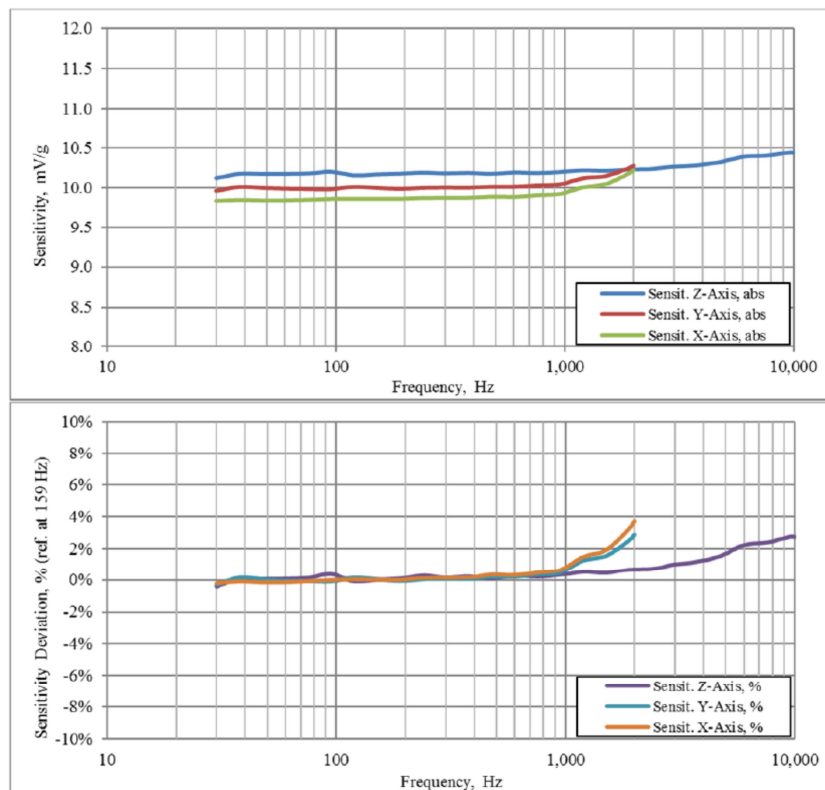

Figure 5a & b. Frequency response of an accelerometer Kistler type 8793A500 calibrated in x-, y- and z- axes from 30 Hz to 2 kHz and 30 Hz to 10 kHz, respectively.

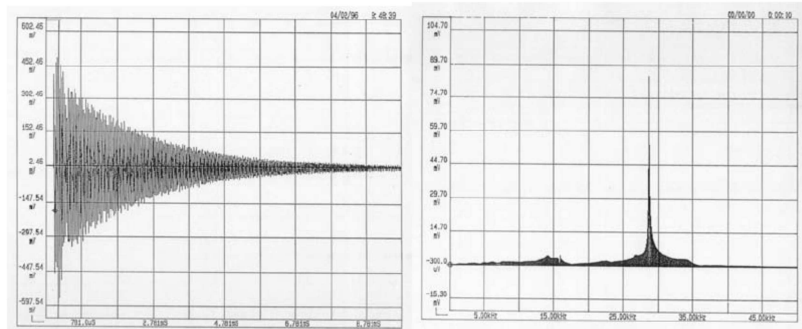
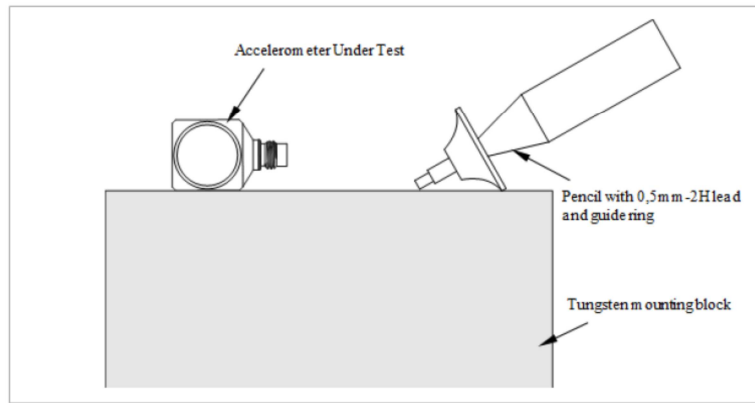

Figure 6a. Characterization by lead breaking of the resonance frequency of an Acoustic Emission Sensor mounted on a tungsten cube (so called HSU-NIELSON according to ASTM E976-10) [3].

Figure 6b & c. Analysis of the transient response with FFT.

High frequent structural borne noise has been recorded and evaluated to improve the crash recognition of passenger protecting systems in automotive control systems during car impact testing [8, 9]. During the deformation of mechanical structures, mechanical force or stress changes occur, which are related with the propagation of high frequent elastic stress waves.



Figure 7. New generation of triaxial accelerometers KISTLER type 8672A, 8763B (ceramic shear), 8766A50 and 8766A500BH (PiezoStar®) for a measurement range of 5 g to 2000 g.

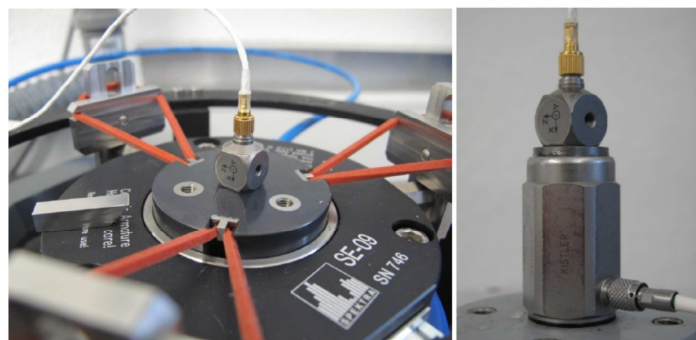

Figure 8a. Frequency response of a Kistler 8766A500AB triaxial accelerometer along x and z axes directly mounted to reference (results in Fig. 9).

Figure 8b. Frequency response in phase and sensitivity of a Kistler 8766A500AB triaxial accelerometer along x and z axes directly mounted to reference.

The usual control systems inside the car record the de-acceleration of the vehicle up to 400 Hz as a rigid body motion. Extending the range of the crash sensor up to 25 kHz, it allows the crash recognition of the deforming car structure to use the evaluation of vehicle structure borne noise of propagating waves in order to increase the system performance with a single central control unit having an internal sensor position. Fig. 10 shows the time varying FFT-spectrum of the wideband structure borne noise signal over time during a vehicle impact.

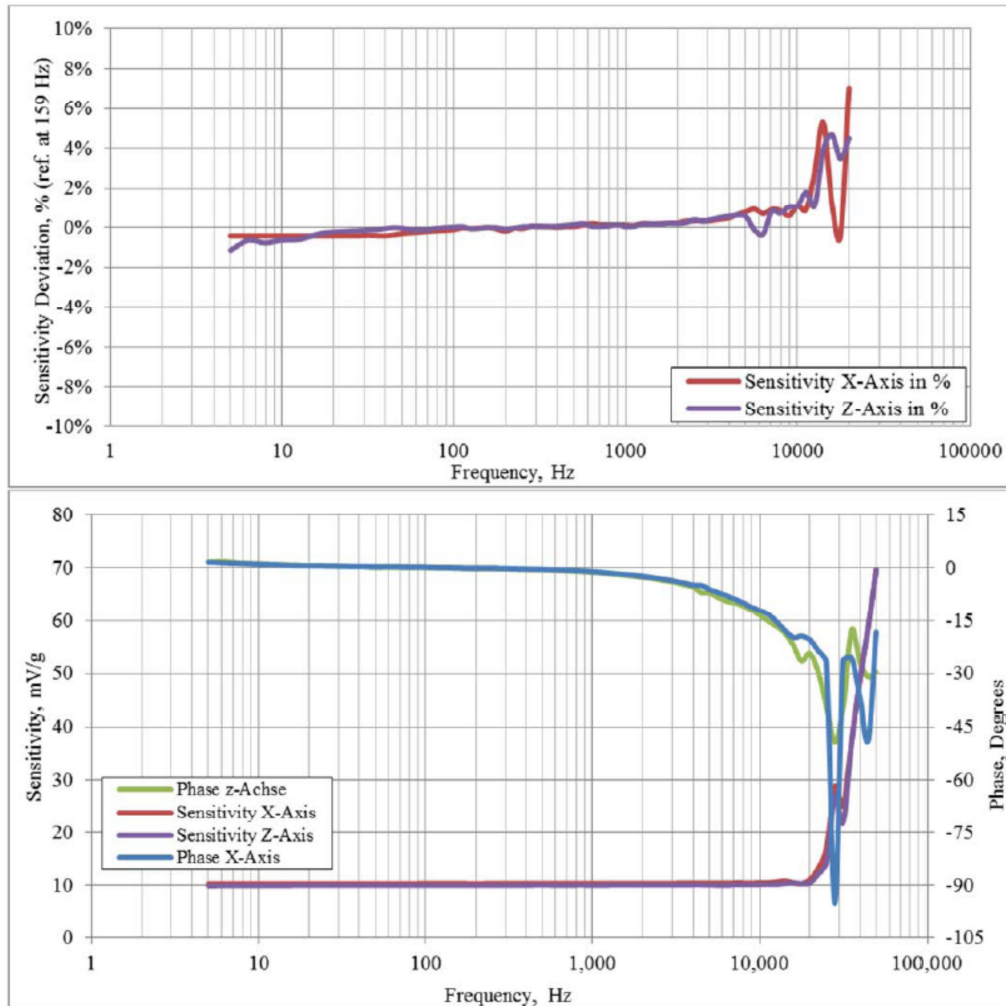

Figure 9a. Frequency response of a Kistler type 8766A500AB mounted in X-and Z-direction on the armature of a SPEKTRA SE-09 air bearing shaker.

Figure 9b. Frequency response in sensitivity and phase of the same sensor along x- and z-axes directly mounted to the reference face of a 'back-to-back' reference accelerometer Kistler type 8076K. See Fig. 8 for mounting configuration along x-axis.

During the evaluation phase, the triaxial accelerometer type 8766A500 has been approved to validate the internal sensor signal of the vehicle internal crash control board. The methodology is described in [9].

Further applications are for example in pyroshock testing, environmental simulation testing of products with electro-dynamical shakers in the high frequency range or for friction investigations on slowly gliding-surface bearings.

2. Acoustic emission sensors for high frequency structural borne noise detection

AE sensors are mainly designed for in-process monitoring of continuous or single event signal detection. These sensors enable the measurement of acoustic emission on the surface within a wide frequency range up to 1 MHz. The goals when designing such a sensor are to achieve good and reproducible coupling conditions, a wide and flat frequency response, to make it insensitive to low frequency environmental vibrations, a rugged design and a small size.

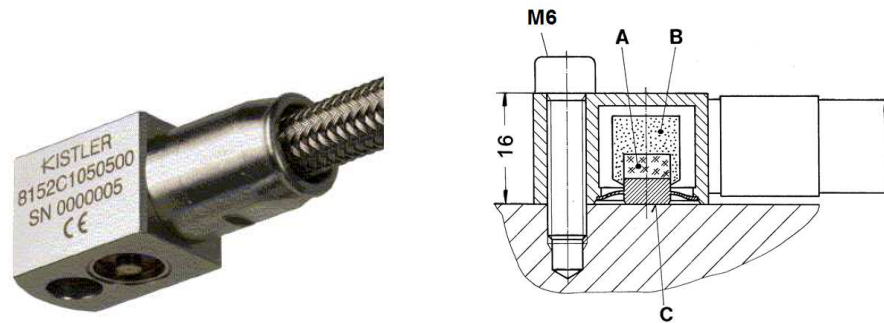

Figure 10. AE sensor Kistler type 8152C. Item A denotes the piezoelectric transducer element, B is the backing, and C is the diaphragm.

Piezoelectric sensing elements are particularly suited to measure AE. The sensing element consists of a piezo-electric ceramic material, which mainly determines the sensitivity and frequency response through its compression and geometrical dimensions. In order to achieve a flat wideband frequency response, the sensor housing has to be well decoupled from the sensing element in order to avoid undesired resonances and dips in the frequency response. To detect Rayleigh waves, the upper frequency limit will be defined by the aperture effect which is caused by the finite size of the diameter of the sensor face [12]. A wideband sensor characteristic is obtained by adding an appropriate back damping to the piezoelectric element, called backing. The backing is usually made of an epoxy filled with high density particles such as tungsten powder, and matched to the acoustic impedance of the Piezoceramic element. It provides high attenuation of the acoustic waves and reduces the resonances allowing for an AE sensor flat frequency response.

The active transducer element of an AE sensor is consisting of a Piezoceramic cylinder, mounted on a thin steel diaphragm. Fig. 10 shows the sensitive element assembled in stainless steel housing, well suited for easy surface installation. The diaphragm is welded on the inside of the housing in such a way that its surface slightly protrudes out of the sensor. When mounting the AE sensor to the surface of a structure, the diaphragm is pressed onto the surface with a defined preload. It allows constant and reproducible coupling conditions at the sensor interface. In such cases, a flat and high quality surface with low roughness as well as a persistent coupling agent such as grease may be needed. The piezoelectric transducer element is decoupled acoustically from the sensor housing and mounting screw. It reduces possible disturbing effects. Because of the small sensor element contact surface, the machining tolerances such as surface roughness and flatness are subjected to a small area only. Coupling is unaffected by the tightening torque of the mounting screw as long as a minimal recommended torque has been applied.

The two Kistler AE sensors are differing in bandwidth and sensitivity by using different thicknesses of piezoelectric element. They cover either a medium frequency range of 50 kHz to 400 kHz with 57 dB sensitivity or a higher one from 100 kHz to 900 kHz with 48 dB sensitivity (dB reference level 1 V/(m/s)).

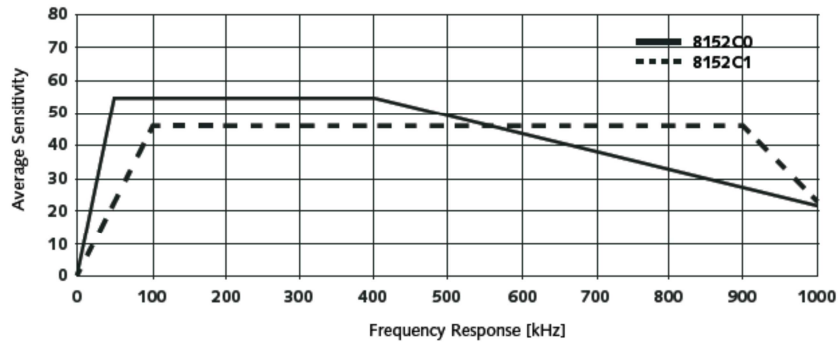

Figure 11. Nominal frequency response of~ the two different AE sensor Kistler type 8152C0 and ~C1.

The AE sensors Kistler Type 8152C are suited for a temperature range from -55°C to 165°C and are available for intrinsic safety within zone 0 and 2 certification [13]. The AE sensor is basically considered as a velocity sensor in contradiction to an accelerometer. This is due to the calibration method employed and directly traceable to a laser vibrometer. The absolute sensor sensitivity decreases with increasing bandwidth. Fig. 12 illustrates the two Kistler sensor types nominal frequency response. Some calibration methods in order to determine the frequency response of AE sensors are described in [10] using primary methods. Although most of the time, those are performed with secondary comparison methods.

The high-pass characteristics of the AE sensor suppress a large part of the low frequency interference signals. Therefore the AE sensor is insensitive to movements in contradiction to accelerometer. It offers a decoupling to low frequency movements. The wideband AE sensor has a uniform sensitivity over the frequency range. Its sensitivity is less than that of resonance type sensors. Thanks to a band pass filtering available in the signal conditioner, individual frequency ranges can be selected in order to focus on the signal of interest. Wideband sensors allow the investigation of the frequency ranges of useful signals, if they are insufficiently known or to assure high flexibility in the signal evaluation. In principal AE signals should always be detected over the full frequency range and as close as possible to the source to allow an optimal signal amplitude. Due to the length and the number of interfaces in the travelling path of the acoustic wave between the AE source and the sensor installation point, high frequency signals are attenuated to a large extent. By the advantage of their small size, these AE sensors are particularly suited for the installation close to the acoustic source, even in limited space.

The AE sensor has been designed with ground isolation and internal Faraday shielding to avoid ground loop effects and reduce noise in the high impedance part of the sensor. To improve the immunity to electromagnetic interference an internal IEPE impedance converter has been integrated into the AE sensor providing a voltage output.

For monitoring operations the relatively complex high frequency AE signal need to be processed with a very high sampling rate. Nowadays modern DAQ's with 24 bit and 4 MHz sampling rate are available [14]. Most of the time, this signal type is used for the evaluation of the process under investigation. In a first step, certain events in the process under test should be correlated to a certain frequency band in the Fourier transformation of the time signal. In a second phase, the raw AE signal can be band pass filtered and rms-averaged. This rms-average signal U_{rms} can be sampled with much lower rates and acquired over time, see Equ. (1). It can also be compared with a reference level to activate a logic limit switch output signal. The block diagram of such a measurement chain is shown in Fig. 13.

$$U_{\text{rms}} = \sqrt{\frac{1}{\tau} \int_0^{\tau} U^2_{\text{AE}} dt}$$

U_{rms} : Voltage after rms-converter
 U_{AE} : Voltage after filtering
 τ : Time constant

AE sensors are used in a very wide range of applications. Typical the time acoustic emissions will be generated through dislocation movements, phase transformations or crack formations and extensions in solid state materials [15] or friction mechanisms [16]. They will be used for monitoring in grinding or polishing processes of glass or metal surfaces, sealing of valves on engines or high pressure industrial compressors for chemical plants, the determination of coal particle size distribution for power plants [17, 18, 19], industrial metal wire drawing, detection of glass fiber splits or in filament fiber processing [20], punching of metal sheets, needle break detection and more. Often, a second measurand in the process can be helpful as discriminators to identify the event in the process, like applied forces or others.

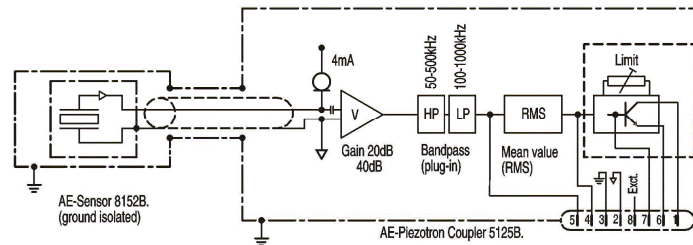

Figure 12. Block diagram of a measurement chain with AE sensor and signal conditioner Kistler type 5125C.

Deep drawing of metal sheets is one of the impressive examples in use of in-process monitoring of AE sensors. Sometimes, basic parts are made on high speed transfer press by deep drawing and punching at up to 300 strokes/min. Nowadays, Industry 4.0 networking of machinery requires to define more parameters to guaranty the product quality and monitor tool wear. Underneath a deep-drawing punch, a force sensor and an AE sensor have been combined and mounted in order to measure in parallel press forces and AE emission in parallel. Fig. 13 illustrates those measurements.

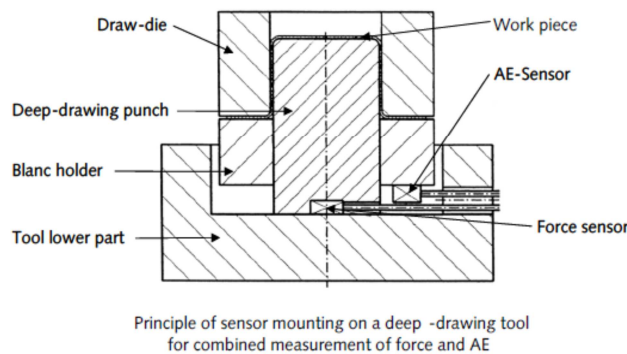

Figure 13. Schematic view on the sensor location for a force and AE sensor on a deep-drawing tool.

The signals shown in Fig. 14 indicates clearly the initial high amplitude AE signal once the deep drawing process is starting similar to what the press force curve is indicating. Just before the press force relaxes again and the metal forming ends, the amplitude of the AE-rms-signal allow to determine a normal good, a necked or a cracked part. This can be clearly used to control the process parameter, to adjust the deep drawing process in the installation, to monitor the state of the tool as well as to filter for good and bad parts in the production phase.

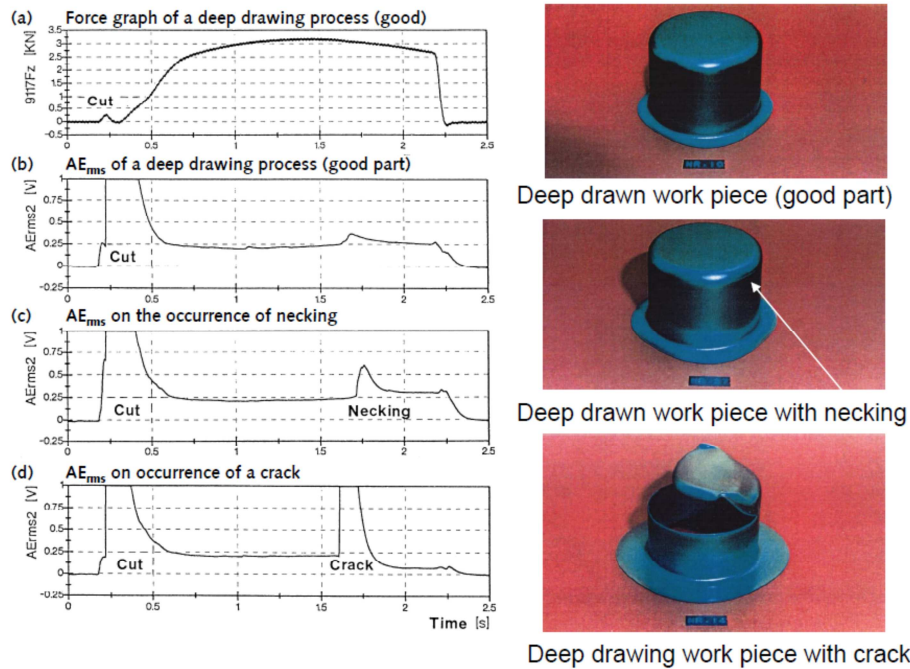

Figure 14. Combined force (a) and AE signals (b-d) for a deep drawing process monitoring of metal sheet forming.

4. Conclusions

New mechanical designs and piezoelectric sensing elements allow us to push the limits of triaxial IEPE accelerometers. Very wide frequency range in the three orthogonal axes can now be achieved. Thanks to those new mechanical designs with integral threads on three faces, we can observe a flat sensitivity over the entire frequency spectrum. This low mass solution appears to be very versatile covering many different applications where formerly several sensor types would have been needed. Finally, the possibility of mounting these sensors in any direction simplifies everyday work during installation. It allows the characterization of structural borne noise up to 12 kHz within 5% sensitivity deviation with a traceable calibration or even higher, but wider deviation. Higher frequency limits can be achieved, if larger sensitivity deviations are accepted and signal attenuation did not happen.

In the frequency range from 50 kHz to nearly 1 MHz, AE sensors are widely used for various processes monitoring in order to insure product quality, process safety, improvement of process efficiency and more.

Both sensor types are used to measure structural borne noise in this very wide frequency range. Between 20 kHz to 50 kHz might be a gap, where both sensor types are not properly suited. It is usually filled with accelerometers under mounted resonance conditions. This requires some precautions and will show highly non-linear amplitude frequency response. This requires very stiff seismic elements, and stiff crystalline piezoelectric materials that can be seen in the latest accelerometer designs.

References

- [1] Th. Petzsche, H. Müller. Chapter 4: Beschleunigung in „Handbuch der Mess- und Automatisierungstechnik in der Produktion“, Hsg.: H.-J. Gevatter, U. Grünhaupt. Springer Verlag, 2006.
- [2] Methods for the calibration of vibration and shock transducers: DIN EN ISO 16063-1x und DIN EN ISO 16063-2x.
- [3] ASTM E976 – 10: Standard Guide for Determining the Reproducibility of Acoustic Emission Sensor Response.
- [4] Accelerometer Resonance Testing described in DIN EN ISO 5743-xx and DIN EN ISO 16063-32 in:
Methods for the calibration of vibration and shock pick-ups;
ISO 5347-14:1993, Part 14: Resonance frequency testing of undamped accelerometers on a steel block.
ISO 5347-22:1993, Part 19: Accelerometer Resonance Testing.
Methods for the calibration of vibration and shock transducers:
ISO DIS 16063-32 "Methods for the calibration of vibration and shock transducers - Part 32:
Resonance testing (Rev. for ISO 5347-14:1993).
- [5] ENDEVCO Handbook of Shock and Vibration Measurement Technology; ENDEVCO, San Juan Capistrano, CA, USA, 1988.
- [6] Th. Petzsche; A. Cook; M. Dumont. Triaxial Accelerometer, High Frequency Measurement and Temperature Stability Considerations, Proc. of the XXXII. International Modal Analysis Conference, Orlando, USA, Feb. 2-3, 2014.
- [7] Kistler Data sheets to the types 8762A, 8763B, 8766A50 and 8766A250/500 at www.kistler.com, 2016.
- [8] http://www.tasler.de/storage/med/media/presseinfos/presseeng/151_Tracking_down_structure-borne_sound Conti-Report-Final_incl Picture.pdf, 2016.
- [9] Christian Lauerer, Paul Spannaus and Thomas Bradmeier: Acquisition and evaluation of mechanical high-frequency waves in car crash for improved crash detection of occupant protection systems; in Sensoren und Messsysteme 2010; VDE Verlag Berlin Offenbach; ISBN 978-3-8007-3260-9.
- [10] V. Liebig; Dr. E. Pridöhl; St. Lohse-Koch; N. Hoppe; Dr. Cl. Cavaloni, Dr. A. Kirchheim. Absolute Calibration of AE sensors with Laser Induced Surface waves, Proc. of the 23rd European Conf. on Acoustic Emission Testing, Vienna, Austria, May 6-8, 1998.
- [11] C. Cavaloni; A. Kirchheim. New Acoustic Emission Sensors for In-Process Monitoring, Proc. of the 12th Int. Acoustic Emission Symp, Sapporo, Japan, Oct. 17-20, 1994.
- [12] M. Greenspan: The NBS conical transducer analysis, J. Acoust. Soc. Am., Vol. 81(1987), pp.173-183.
- [13] Kistler data sheet to type 8152C at www.kistler.com, 2017.
- [14] LTT Tasler, data sheet for for data recorder LTT24 at www.tasler.de, 2017.
- [15] Jens Trampe Broch. Mechanical Vibration and Shock Measurements. Brüel & Kjær; 1984; chapter 9.
- [16] Markus Dickerhof. Potentials of acoustic emission analysis in monitoring and diagnosis of tribological systems, Dissertation at Inst. for Product Development, Karlsruhe Institute of Technology; 2011; ISSN 1615-8113.
- [17] M. Biscuola, M. Gualerci, I. Brunetti, D. Pestonesi, N. Rossi, S. Collura, F. De Angelis. An Advanced Monitoring and Diagnostic System for Coal Mill Optimization in Thermoelectric Power Plants, Proc. of the Power Gen, Amsterdam; June 9-11, 2015.
- [18] A.Cook, S. Collura, M. Dumont, T. Urbank; Continuous Monitoring of Powder Size Distribution using High Temperature ATEX Acoustic Emission Sensors, Proc. of the 31st Conference of the European Working Group on Acoustic Emission (EWGAE) – Th.3.B.2., Dresden, Germany, Sept. 3-5, 2014.
- [19] S. Collura, D. Possanzini, M.Gualerci, L.Bonelli, D.Pestonesi. Coal mill performances optimization through non-invasive online coal fineness monitoring, proc. of the Power Gen, Wien, June 4-6, 2013.
- [20] Gunnar Henrik Seide. Akustische Online-Überwachung und Strömungssimulation von Verwirbelungsprozessen bei der Filamentgarnverarbeitung. Dissertation at RWTH Aachen, Faculty for Mechanical Engineering, 2008.